

THIS COPY IS PROVIDED ON A RESTRICTED BASIS AND IS NOT TO BE USED IN ANY WAY DETRIMENTAL TO THE INTERESTS OF PANDUIT CORP.

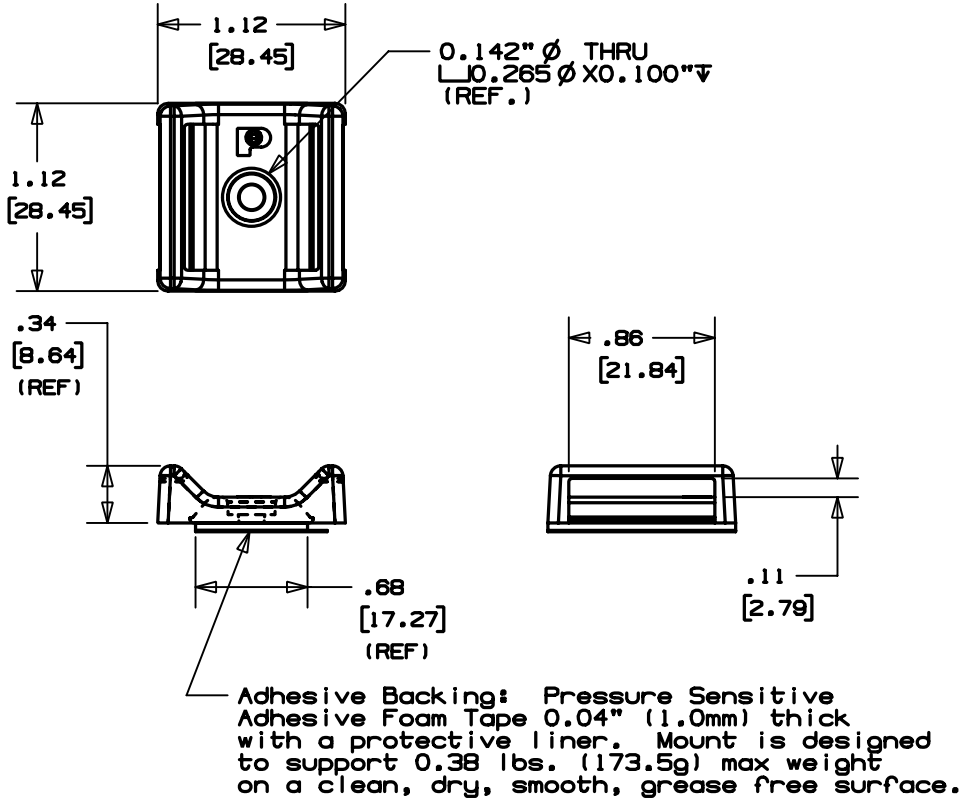

PANDUIT PART NO. (*)	WEIGHT lbs / 100 (g) / pcs.
ABMT-_-_-	NO ADHESIVE 0.64 (291.4)
	WITH ADHESIVE 0.65 (294.8)

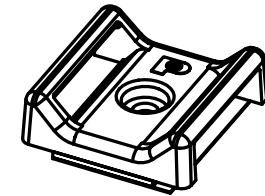
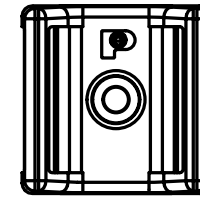

SCALE: FULL

**NOTES:**

- SEE CURRENT PRICE SHEET FOR PART NUMBER SUFFIX DESIGNATION FOR PACKAGE SIZE AND COLOR.
- A SUFFIX REPRESENTS RUBBER ADHESIVE  
 -AT SUFFIX REPRESENTS ACRYLIC ADHESIVE  
 -S6 SUFFIX, NO ADHESIVE: SCREW APPLIED WITH A #6-32 BUTTON HEAD CAP SCREW.
- ABMT-A HAS A MAXIMUM CONTINUOUS OPERATING TEMPERATURE OF 120°F (49°C).  
 ABMT-AT HAS A MAXIMUM CONTINUOUS OPERATING TEMPERATURE OF 180°F (82°C).

DIMENSIONS IN BRACKETS ARE METRIC [ mm ]	
CAD FILENAME/LAYER: G02471CB_PB_ABMT_01	
<b>PANDUIT</b> CORP. TINLEY PARK, ILLINOIS	
ADHESIVE BACKED "TAK-TY" MOUNT (ABMT-_-_-)	
UNLESS OTHERWISE SPECIFIED, DIMENSIONAL TOLERANCES ARE: (.X) ±0.05 (1.3) (.XXX) ±0.010 (0.25) (.XX) ±0.02 (0.5) ANGLES ± 5°	UNLESS OTHERWISE SPECIFIED, ALL DIMENSIONS ARE GIVEN IN INCHES, THIRD ANGLE PROJECTION.
DRAWN BY JAD	MAT'L: NYLON 6/6
DATE 1/28/02	SCALE NONE
REV	DRAWING NO. GB2471CB
DATE	DWG SIZE A
BY	
CHK	
DESCRIPTION	
ECN - R	
CUST	
SUP	

1	2/11/05	JAD		1.12 was 1.10	GB2471CB	1			
REV	DATE	BY	CHK	DESCRIPTION	ECN - R	CUST	SUP		